

GSS #150

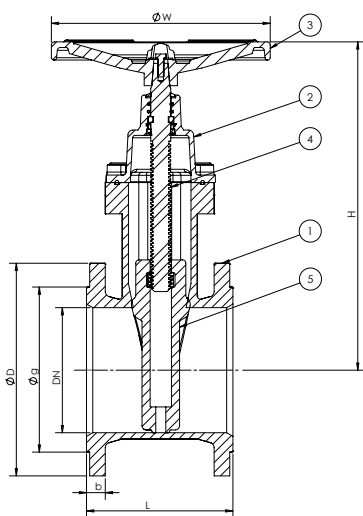

F5



F4

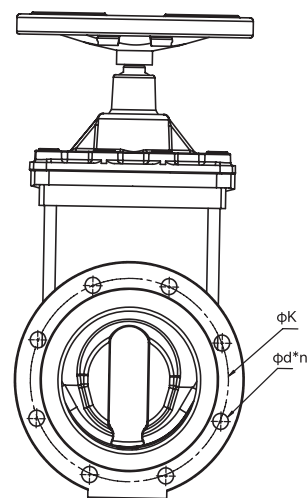

General Specification

Maximum Working Temperature 110 °c

Standards

Design: EN 1171

Face To Face Dimensions: EN558 (F4, F5)

Machining And Drilling Of Flanges: ANSI/ASME B16.42 #150

Test And Inspection: EN12266-1

Applications

Water, Waste Water And HVAC

ویژگی های محصول

ماکزیمم دمای کاری 110 درجه سلسیوس

استاندارد

طراحی: EN1171

وجه تا وجه: EN558 (F4, F5)

ماشین کاری و سوراخ کاری فلنج ها: ANSI/ASME B16.42 #150

تست و بازرسی: EN12266-1

کاربرد

صنایع آب و فاضلاب، تاسیسات حرارتی-برودتی و تبویه مطبوع

NO	Part Name	Material	Spare Part
1	Body	GGG50	
2	Bonnet	GGG50	✓
3	Handwheel	Stamped Steel / GGG40	✓
4	Stem	AISI 420	✓
5	Wedge	GGG40 Coated with EPDM / NBR	✓
6	Oring	EPDM / NBR	✓

DN (mm)	L	H	W	D	K	g	b	d*n	Weight (kg)
50	150	237.5	140	165	125	99	19	19*4	10.5
65	170	282.5	160	185	145	118	19	19*8	12.5
80	180	315	200	200	160	132	19	19*8	20
100	190	355	200	235	190	156	19	23*8	23
125	200	420	250	270	220	184	19	28*8	37.5
150	210	467.5	250	300	250	211	20	28*8	43
200	230	560	315	360	310	274	22	28*12	66.5
250	250	653	400	425	370	330	24.5	31*12	106
300	270	728	500	485	430	389	27.5	31*16	138